

SPECIFICATION SHEET: S026***Front Line Leisure Cubicle***

Bespoke: We have the ability to customise our products to meet your requirement and space, providing solutions for awkward corners, uneven floors or even curved walls.

After-sales Service: All of our products are supported by the Helmsman Service team who provide technical advice, maintenance schemes, prompt delivery of replacement keys/parts and product refurbishment. Contact them on 01284 727633 or email service@helmsman.co.uk

- Health & Safety: Lockers must be firmly secured to wall or floor and fixed together in runs for safety purposes. If applicable, install in accordance with specific product instructions.
- All dimensions are nominal.
- To enable us to interpret your requirements accurately, please state at time of enquiry/order the choice of locker type, colour, locking and nesting arrangement and delivery requirement.
- The products described in this specification sheet herein are the subjects of patent, trademark, design and copyright protection or application thereof.
- In the interest of efficiency and service to our customers, the company reserves the right to modify the specifications of any of its products.

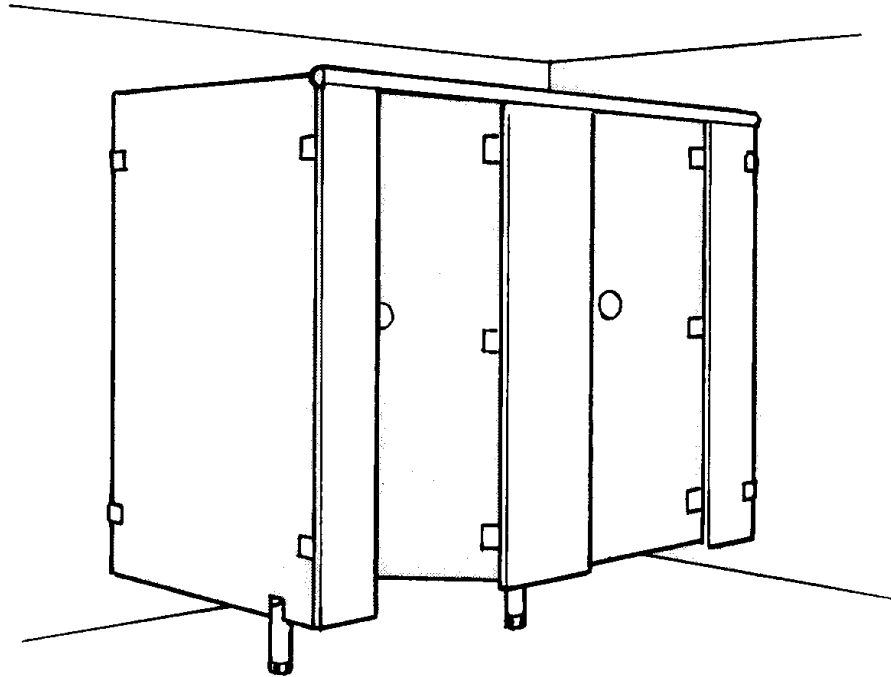

SPECIFICATION SHEET: S028

FRONT LINE CUBICLE RANGE SYSTEM ONE



Detailed Product Specification

Cubicles suitable for wet and dry toilet & changing environments in a package designed to provide optimum strength and style at an affordable price.

- Doors, partitions and pilasters: Solid phenolic grade laminate, 12/13 mm thick, black core. All exposed edges smoothed and radiused.
- Finish/Colour: Doors, partitions and pilasters: Extensive colour choice from helmsman standard colour range. Hardware/Door Furniture: SAA, black or white as standard. Other RAL/BS colours are available at supplementary cost
- Head Rail: Strong, rounded extruded aluminium channel which stabilises and strengthens cubicle. It is mechanically fixed to pilasters.
- Door Latch/Indicator Bolt: Ergonomic slide operated indicator bolt with circular face plate, integral rubber door buffer and emergency release facility.
- Door Hinge: Each door fitted with 3 heavy-duty, through fixing hinges, incorporating anti-finger trap and anti-lift design. Hinges can be adjusted so door can be allowed to stay open, closed or ajar when not in use. Hinges can be fitted so doors open outwards.
- Pedestal Leg: Heavy-duty, 150mm high, providing 30mm adjustment to accommodate uneven floors. Concealed floor fixings and security through fittings.
- Coat Hook: Single circular aluminium coat hook with integral rubber safety buffer.
- Seat: Changing cubicle seats are made of solid grade laminate or hardwood slat (option) and include optional cantilever or standard seat bracket.
- Panel Fixings: Aluminium 'U' brackets with tamper proof fixing for securing panels to each other and to walls. Minimum of 3 to each vertical panel. Security fixings come as standard
- Sizes: The overall height of cubicles is 1950mm. This can be varied to suit specific applications within the limit of the chosen panel specification. Back to back cubicles will be limited to 2500mm overall. Special arrangements can be made for bigger dimensions which may necessitate additional supporting structure.
- Installation: Helmsman offers a full installation service for its products.

HELMSMAN also provide an extensive range of lockers, changing room furniture, toilet/shower cubicles, vanity units, wall linings and panel systems.

After-sales Service: All of our products are supported by the Helmsman Service team who provide technical advice, maintenance schemes, prompt delivery of replacement keys/parts and product refurbishment. Contact them on 01284 727633 or email service@helmsman.co.uk

- Health & Safety: Lockers must be firmly secured to wall or floor and fixed together in runs for safety purposes. If applicable, install in accordance with specific product instructions.
- All dimensions are nominal.
- To enable us to interpret your requirements accurately, please state at time of enquiry/order the choice of locker type, colour, locking and nesting arrangement and delivery requirement.
- The products described in this specification sheet herein are the subjects of patent, trademark, design and copyright protection or application thereof.
- In the interest of efficiency and service to our customers, the company reserves the right to modify the specifications of any of its products.



Helmsman is the trading name of
Sperrin Metal Products Ltd

1 Northern Way, Bury St Edmunds,
Suffolk, IP32 6NH, United Kingdom
Tel: (+44) 01284 727600
Fax: (+44) 01284 727601
www.helmsman.co.uk
sales@helmsman.co.uk